



Operating instructions

Mouse killer



Maschinenfabrik Bermatingen GmbH & Co. KG

Kesselbachstraße 2
D-88697 Bermatingen
Germany

Phone +49 (0) 75 44 / 95 06 - 0
Fax +49 (0) 75 44 / 95 06 - 20
Fax +49 (0) 75 44 / 52 07

Declaration of conformity



for the

Mouse Killer
manufactured by us

Ident.No. 307.00.000

We confirm the compliance with the requirements of the Machinery Directive **2006/42/EC** including its modifications and supplements published up to the present. Corresponding technical documentation can be made available. The following standards and directives were taken into account in the design and manufacture:

DIN EN ISO 12100 – 1+2 :2011

**Safety of machinery
(general, including risk assessment)**

DIN EN ISO 13857-2008

**Safety of machinery
(Safety distances to prevent hazard zones being
reached by upper and lower limbs)**

Authorised person for documentation: Wolfgang Websky. For address, refer to manufacturer.

Bermatingen, Sept. 2010

**Maschinenfabrik
Bermatingen GmbH & Co. KG
Company management**

A handwritten signature in black ink, appearing to read 'Ulrich Gotterbarm', written in a cursive style.

Ulrich Gotterbarm



Table of contents

	Page
Details	4
1. Safety requirements	5
2. Construction and function	7
3. Maintenance	9
4. Technical data	10
Sheets for replacement parts	11
Attachment for motor	14

Details

Address of manufacturer

Maschinenfabrik Bermatingen GmbH & Co. KG
Kesselbachstr. 2
D-88697 Bermatingen, Germany

Phone +49 (0) 75 44 / 95 06 0

Fax +49 (0) 75 44 / 52 07

Maker's plate for your device

Maschinenfabrik Bermatingen GmbH & Co D-88697 Bermatingen • Tel.0 75 44/95 06-0			
Typ	<input type="text" value="humus mouse killer"/>		
Ser.Nr.	<input type="text"/>		
Volt	<input type="text"/>	kg	<input type="text"/>
Amp.	<input type="text"/>	Ph	<input type="text"/>
kW	<input type="text"/>	Bj	<input type="text"/>
MADE IN GERMANY			



Serial number (Ser.Nr.) is located on the maker's plate of your mouse killer. Please enter this serial number here:

Without this serial number, claims under guarantee and queries cannot be processed.

Symbols in these operating instructions

The following symbols are used in these operating instructions:

- This symbol is positioned before activities to be carried out



Indication of danger to humans

Failure to comply with this information can result in hazards to life and limb for people

Attention

Indication of material or personal injury

Information

Positioned before text which provides additional information.

1. Safety requirements



1. Before using the mouse killer, the persons operating the machine must have read the operating instructions, and must comply with the safety requirements!



2. Exhaust gases / Attention



Do not run the motor in an enclosed space!

Always work against the wind, so that the exhaust gases are not inhaled!

(The exhaust gases contain carbon monoxide, a deadly, odourless gas)



3. Fuel (petrol)

Do not remove the tank cap, or refill with fuel, while the motor is hot or is running.

Do not store, spill, or use fuel close to open fuels or equipment such as ovens or heaters which create permanent flames or sparks.

Do not smoke.



4. Noise emissions

You must use suitable hearing protection, and comply with local noise protection regulations.

The A-value equivalent continuous sound pressure level of this machine is approx. 85 dB(A)

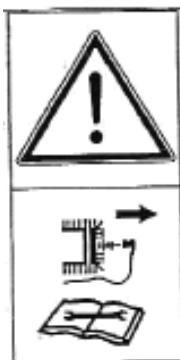

5. Spark plug terminal

Attention!

In order to prevent an unintended motor start, the spark plug cable must be removed before maintenance work. At your own risk the spark plug switch can be switched off because the spark plug cable is difficult to access!



6. Danger of burns

Keep a sufficient distance away from the exhaust unit and the flexible metal hose!

Intended use

The exclusive purpose of the mouse killer is to effectively, cleanly, and humanely to destroy field mice and voles in their runs in open land.

The machine may be used exclusively for its intended purpose.



SAFETY REQUIREMENTS

- The machine may be used only on open land!
- Always work against the wind, so that the exhaust gas is not inhaled!

See section 1/Safety requirements

2. Construction and function

The mouse killer is a robust machine, proven in practical use, for the effective destruction of mice on open land.

- Tilt-resistant construction with good weight distribution.
- The flexible gas hose with exhaust bell makes its work easy.

2.1 Construction

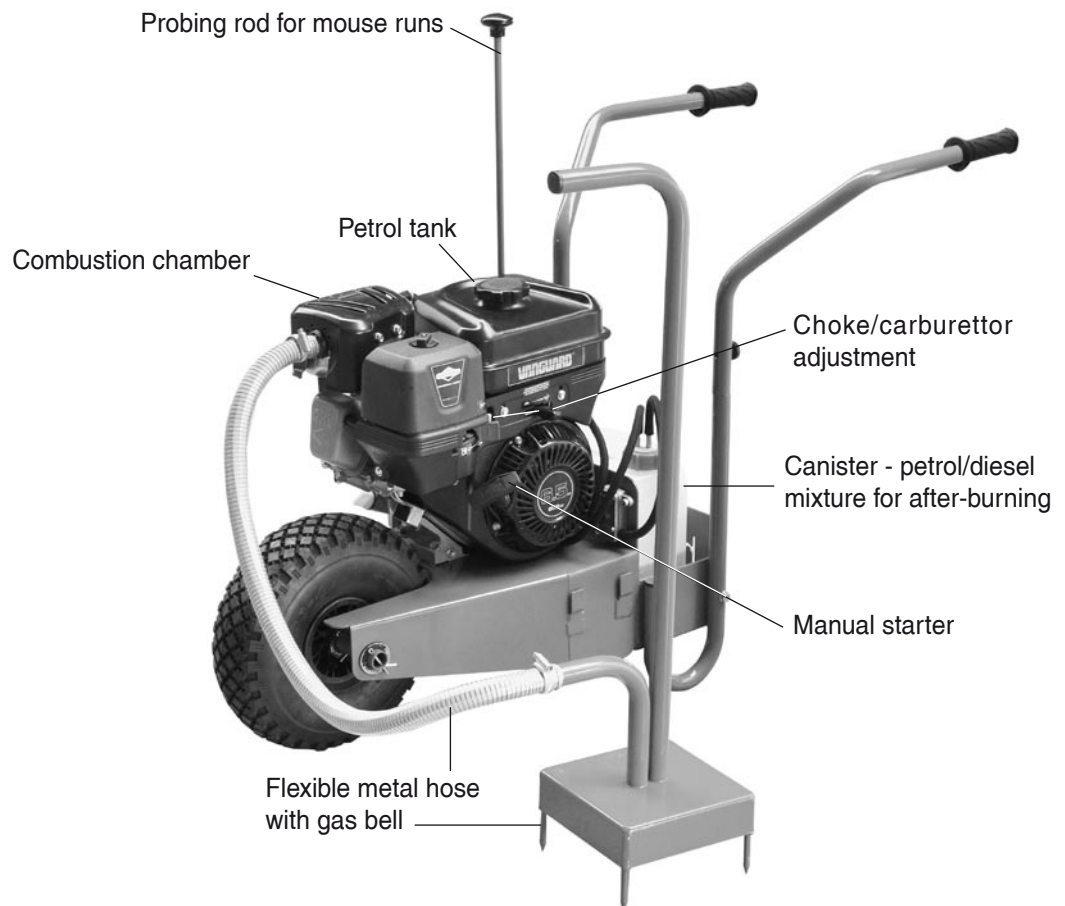

2.2 Function

A diesel/petrol mixture is dosed and injected into the modified silencer by means of a vacuum pump. The fumes generated thereby are ducted into the earth by means of a flexible metal hose and a metal bell.

Thus it takes 5 minutes (even at medium rotational speed) for the industrial motor to expel 2 m³ of air from the mouse runs.

2.3 Commissioning

Before commissioning the machine, the section on safety requirements must be read and complied with

2.31 Making the machine ready for use

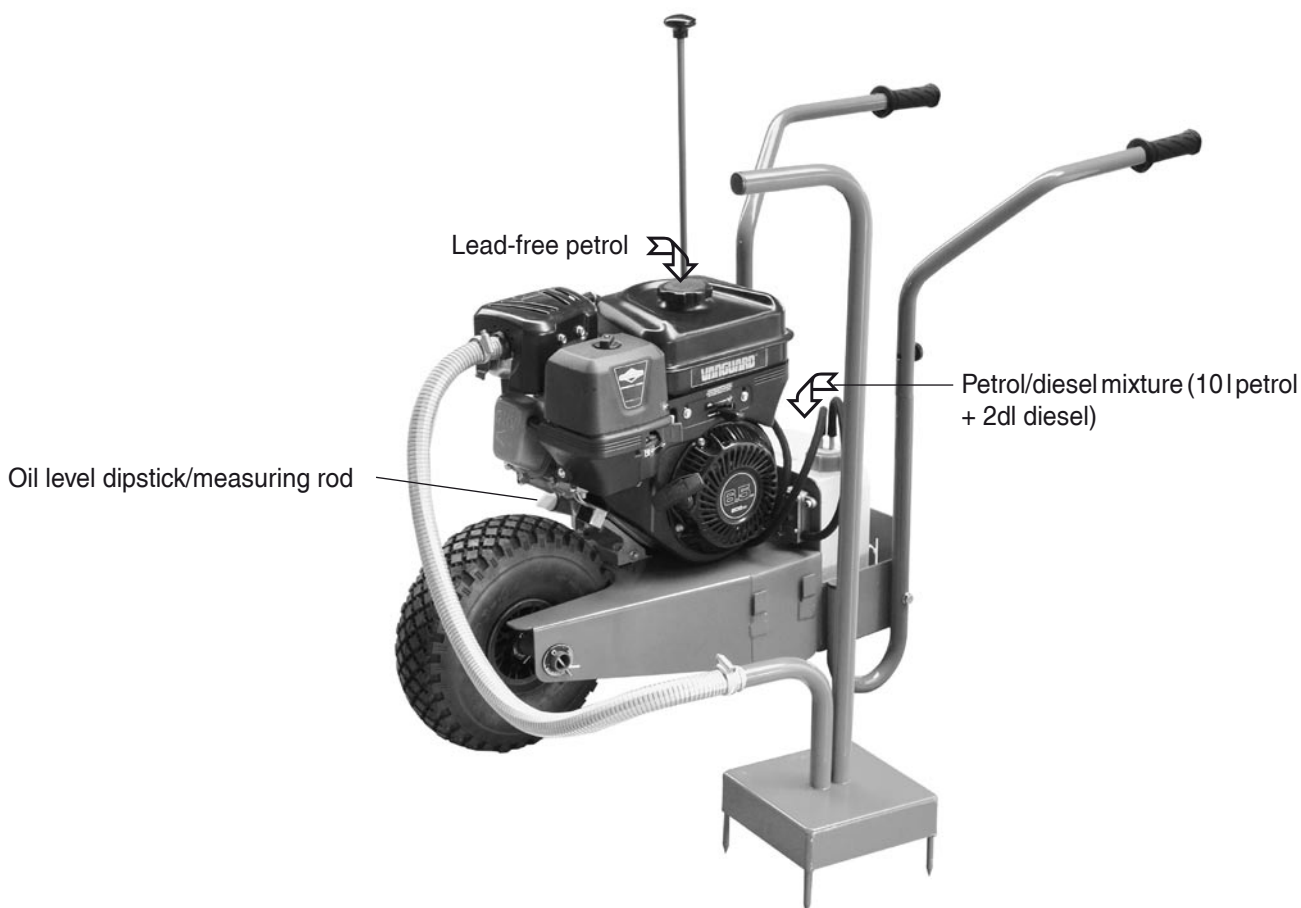

- Fill petrol tank for motor with lead-free petrol
- Fill canister for after-burning with lead-free petrol/diesel mixture (Ratio of mixture 2% = 10 l petrol + 2 dl diesel)
- Check oil level in motor
Oil SAE 15W40
Do not use any oil supplements or additives

2.32 Start the motor.

- Set the choke position to CHOKE
- Set fuel to full throttle (,hare' position)
- Pull the handle of the manual starter until resistance is felt, then pull vigorously!
- When the motor starts, set the throttle to the idle position after approx. 1 minute. (see also attachment for motor).



2.33 Correct use of the mouse killer

- Allow the machine to run for about 5 minutes (operating temperature), then open the shut-off valve
- Probe the mouse run with the probing rod and extend the hole to about 5 cm.

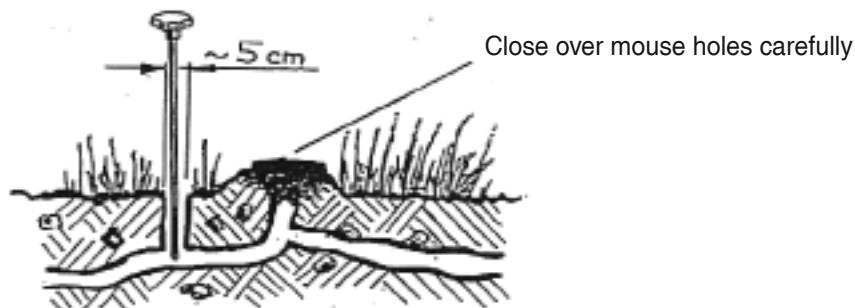

- Place the gas bell firmly onto the hole.



Attention: Metal hose becomes hot, do not touch!

Information: Always work against the wind, so that the gas is not inhaled!

- Allow to run for 5 minutes at full revs (sufficient for a 50 m system of runs)

Information: If indicating smoke escapes, close off the affected holes.

Information: Close over the holes in the runs which have been gassed so that the gas can escape only slowly.

- For further work, set the throttle to the idling position or stop the motor.
- Then flatten the heaps of earth, and press the holes closed,

Check: After a few days check whether the mouse holes have been broken open, or whether there are new piles of earth due to mice from ungassed runs.

2.34 Stop the motor

Set the throttle to the STOP position

3. Maintenance

All parts of the mouse killer are powder-coated, and therefore provide secure rust protection.

Cleaning

Clean the mouse killer after use.

After wet-cleaning the machine, wipe it dry with rags.

Store the machine in a protected dry place.

Motor

Check oil level in motor! Oil SAE 15W40

Do not use any oil supplements or additives

(see attachment for motor for maintenance instructions)

Repairs

For repair work, contact Maschinenfabrik Bermatingen

Tel. +49(0)7544-9506-0

4. Technical data

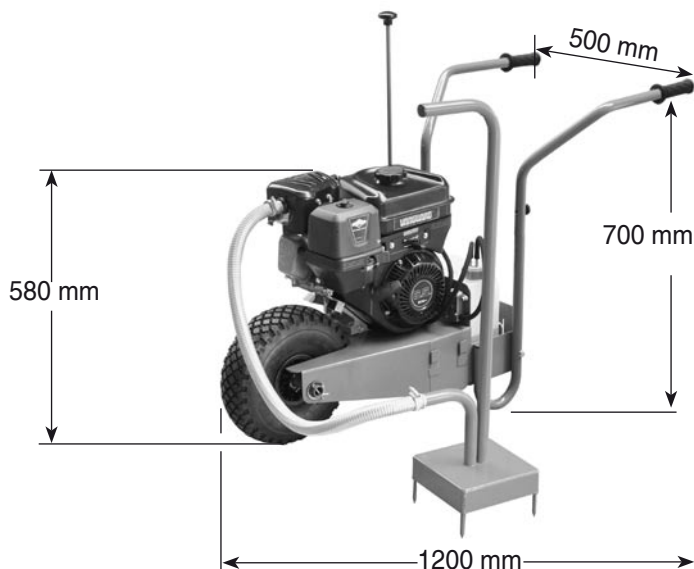

Dimensions

L x H x W 1200 mm x 580 mm x 500 mm

Machine data

Weight of machine (empty) 38 kg
with fuels 45 kg

Motor characteristics as per SAE code J1995

Motor power approx. 0.5 kW
Rotational speed (reference) 3060 rpm
Fuel consumption approx. 0.7 litres/hour

Fuel for motor

Lead-free petrol, minimum octane rating 95

ATTENTION: You must observe: Motor datasheet pp. 12 to 19

Additional combustion

Lead-free petrol/oil mixture approx. 2.5 litres/hour
Mixture ratio 1:50 10 l petrol+ 2 dl diesel

Exhaust gas values

Total exhaust gas output 75.0 to 115.0 l/min
Carbon monoxide 3.0 to 9.2 l/min
Carbon monoxide - volume percentage 4.0 -8.0
Hydrocarbons 4.0 to 45.0 l/min
Hydrocarbons - volume percentage 5.4 - 38.9
Values at engine speed of 3060 rpm

Noise emission

The A-value equivalent continuous sound pressure level of this machine is approx. 85 dB (A)

Values at engine speed of 3060 rpm

SHEET FOR REPLACEMENT PARTS



1 x Nozzle
30700024



1 x Petrol vacuum pump
30700025



1 x T-piece petrol hose
30700026



1 x shut-off valve
30700023



1x petrol hose 1.0 m (for adjustment to size)
30700022

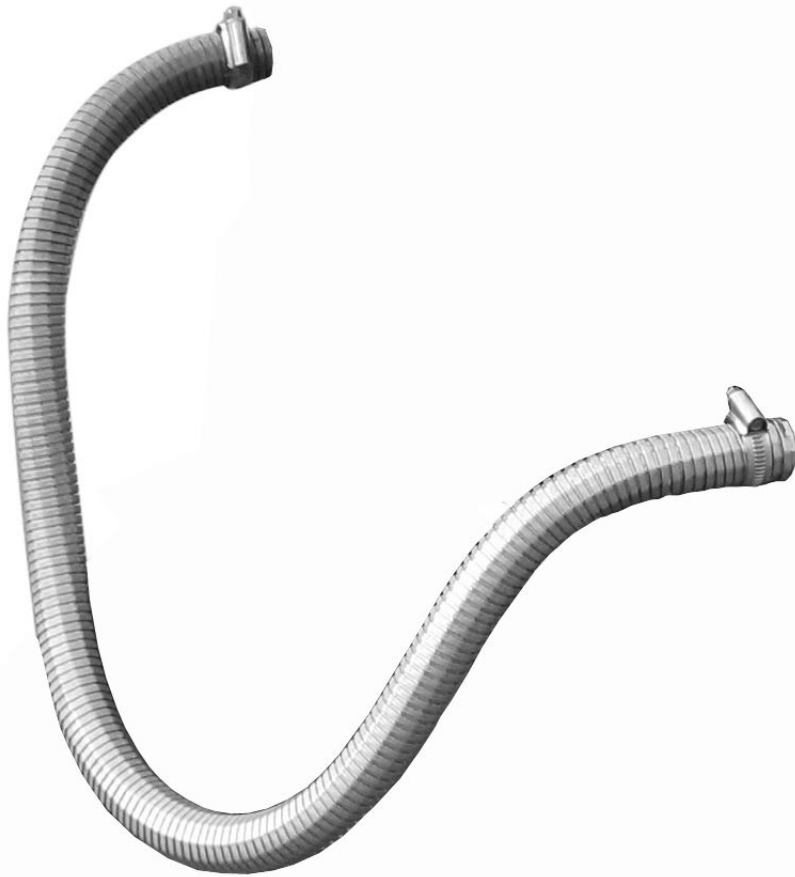

1x flexible metal hose
30700019



1 x cover for combustion chamber
30700021



2 x hose clips 20-40 x 12 mm
for exhaust gas hose
30700020



1 x gas bell
30700011



Handle (left)
30700015

Handle (right)s
30700016



1 x probing rod
30700010



2 x grips
30700017



3 x end cap
30700018



1 x wheel
30700012



1 x intake fitting
30700014



1 x container for after-burning mixture
30700013



COMMERCIAL POWER



Model 130000
190000

Vanguard™

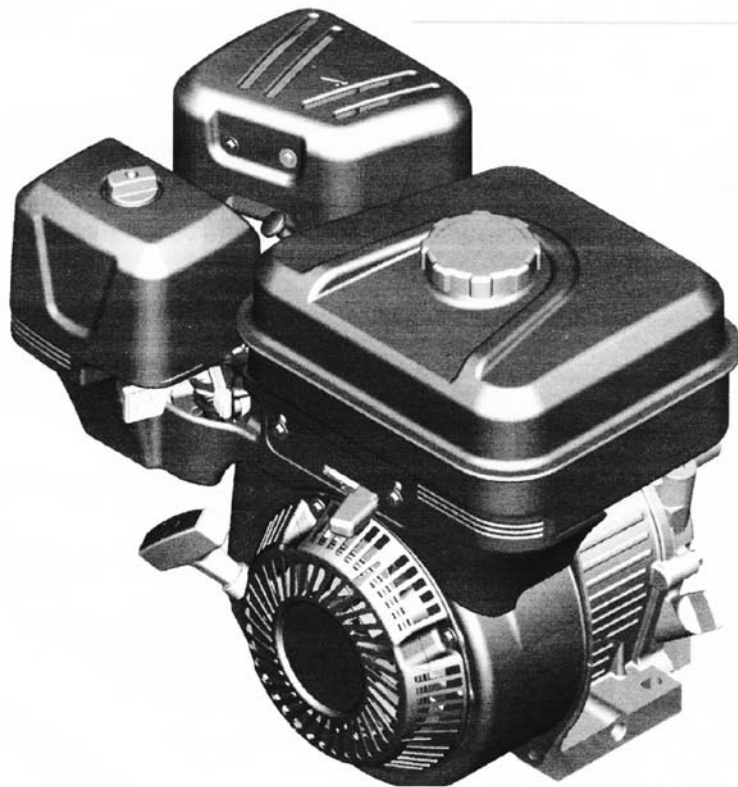

Briggs & Stratton is a registered trademark of Briggs & Stratton Corporation

© 2011 Briggs & Stratton Corporation, Milwaukee, WI, USA. All rights reserved.

Form No. 279770WST
Revision: A

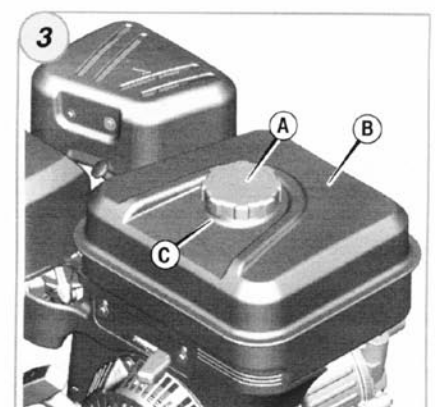
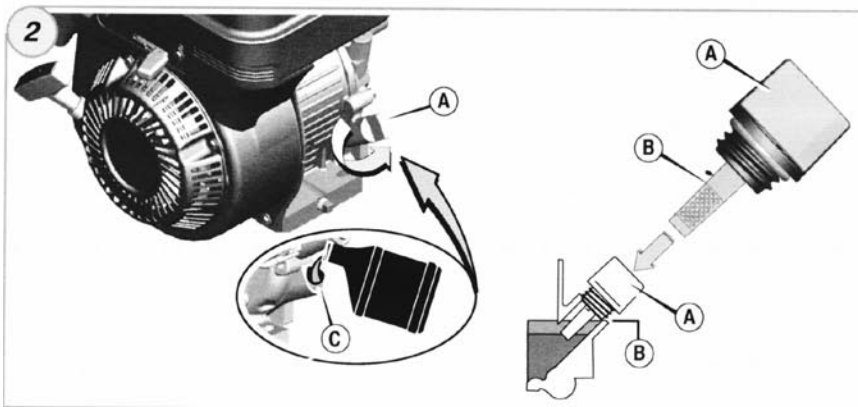
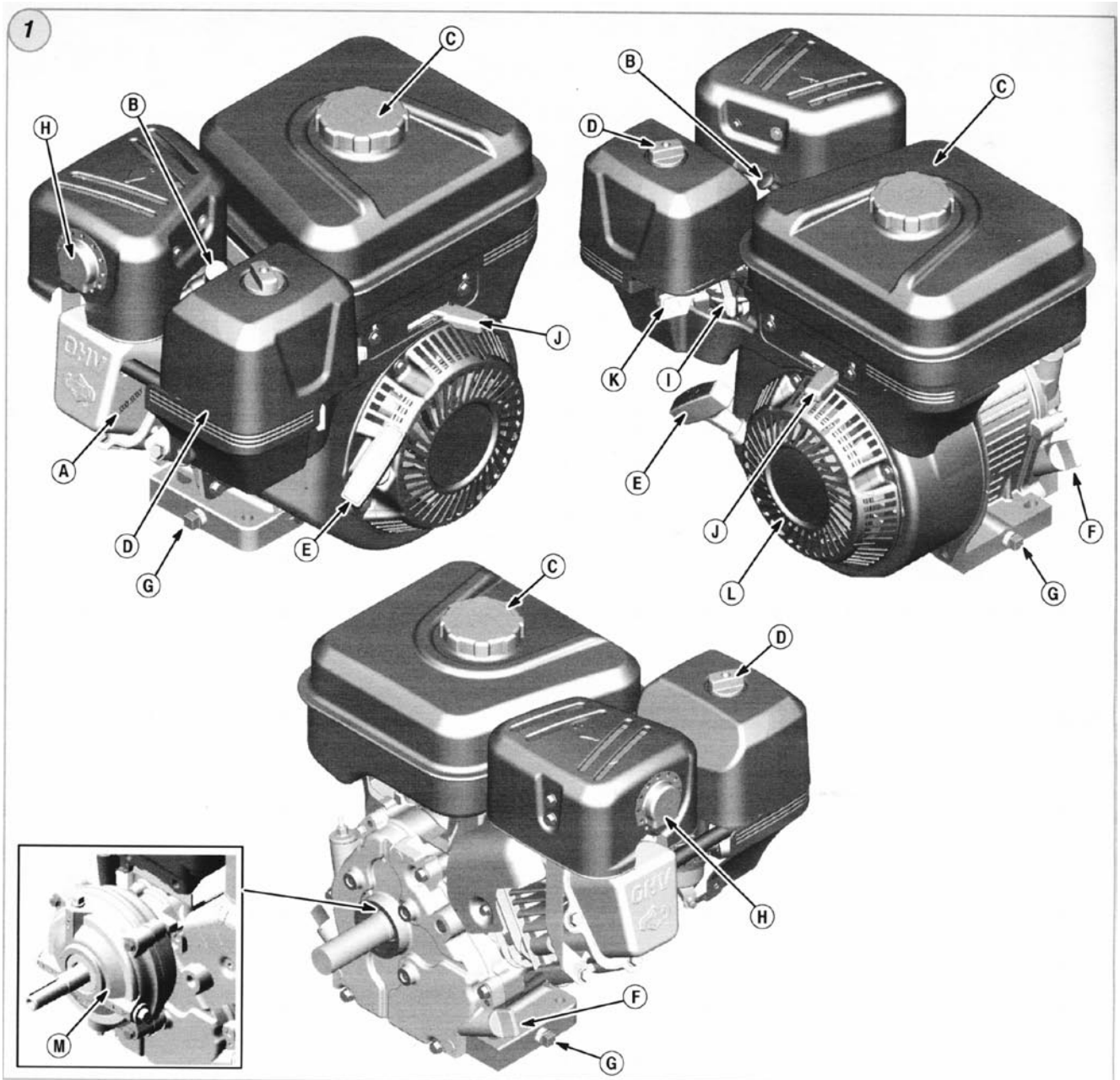

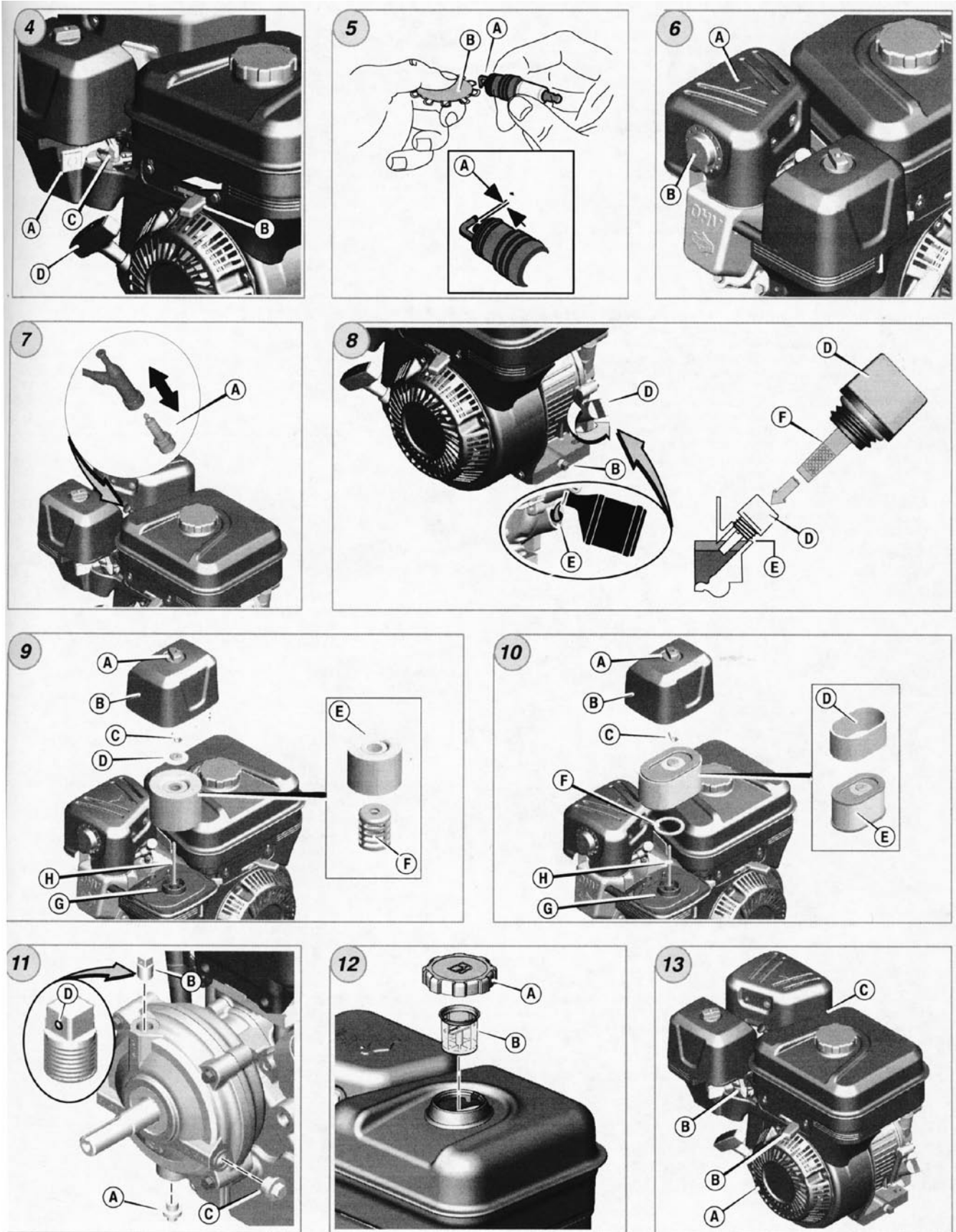



General Information

This manual contains safety information to make you aware of the hazards and risks associated with engines and how to avoid them. It also contains instructions for the proper use and care of the engine. Because Briggs & Stratton Corporation does not necessarily know what equipment this engine will power, it is important that you read and understand these instructions and the instructions for the equipment. **Save these original instructions for future reference.**

For replacement parts or technical assistance, record below the engine model, type, and code numbers along with the date of purchase. These numbers are located on your engine (see the *Features and Controls* page).

Date of purchase: _____
MM/DD/YYYY

Engine model: _____
Model: Type: Code:

Power Rating

The gross power rating for individual gas engine models is labeled in accordance with SAE (Society of Automotive Engineers) code J1940 (Small Engine Power & Torque Rating Procedure), and rating performance has been obtained and corrected in accordance with SAE J1995 (Revision 2002-05). Torque values are derived at 3060 RPM; horsepower values are derived at 3600 RPM. Net power values are taken with exhaust and air cleaner installed whereas gross power values are collected without these attachments. Actual gross engine power will be higher than net engine power and is affected by, among other things, ambient operating conditions and engine-to-engine variability. Given the wide array of products on which engines are placed, the gas engine may not develop the rated gross power when used in a given piece of power equipment. This difference is due to a variety of factors including, but not limited to, the variety of engine components (air cleaner, exhaust, charging, cooling, carburetor, fuel pump, etc.), application limitations, ambient operating conditions (temperature, humidity, altitude), and engine-to-engine variability. Due to manufacturing and capacity limitations, Briggs & Stratton may substitute an engine of higher rated power for this Series engine.

Operator Safety

SAFETY AND CONTROL SYMBOLS



The safety alert symbol is used to identify safety information about hazards that can result in personal injury. A signal word (DANGER, WARNING, or CAUTION) is used with the alert symbol to indicate the likelihood and the potential severity of injury. In addition, a hazard symbol may be used to represent the type of hazard.

- DANGER** indicates a hazard which, if not avoided, **will result in death or serious injury.**
- WARNING** indicates a hazard which, if not avoided, **could result in death or serious injury.**
- CAUTION** indicates a hazard which, if not avoided, **could result in minor or moderate injury.**

NOTICE indicates a situation that **could result in damage to the product.**

WARNING
Certain components in this product and its related accessories contain chemicals known to the State of California to cause cancer, birth defects, or other reproductive harm. Wash hands after handling.

WARNING
The engine exhaust from this product contains chemicals known to the State of California to cause cancer, birth defects, or other reproductive harm.

WARNING
Briggs & Stratton does not approve or authorize the use of these engines on 3-wheel All Terrain Vehicles (ATVs), motor bikes, fun/recreational go-karts, aircraft products, or vehicles intended for use in competitive events. Use of these engines in such applications could result in property damage, serious injury (including paralysis), or even death.

NOTICE: This engine was shipped from Briggs & Stratton without oil. Before you start the engine, make sure you add oil according to the instructions in this manual. If you start the engine without oil, it will be damaged beyond repair and will not be covered under warranty.

WARNING
 Fuel and its vapors are extremely flammable and explosive.
 Fire or explosion can cause severe burns or death.

When Adding Fuel

- Turn engine off and let engine cool at least 2 minutes before removing the fuel cap.
- Fill fuel tank outdoors or in well-ventilated area.
- Do not overfill fuel tank. To allow for expansion of the fuel, do not fill above the bottom of the fuel tank neck.
- Keep fuel away from sparks, open flames, pilot lights, heat, and other ignition sources.
- Check fuel lines, tank, cap, and fittings frequently for cracks or leaks. Replace if necessary
- If fuel spills, wait until it evaporates before starting engine.

When Starting Engine

- Ensure that spark plug, muffler, fuel cap and air cleaner (if equipped) are in place and secured.
- Do not crank engine with spark plug removed.
- If engine floods, set choke (if equipped) to OPEN/RUN position, move throttle (if equipped) to FAST position and crank until engine starts.

When Operating Equipment

- Do not tip engine or equipment at angle which causes fuel to spill.
- Do not choke the carburetor to stop engine.
- Never start or run the engine with the air cleaner assembly (if equipped) or the air filter (if equipped) removed.

When Changing Oil

- When you drain the oil from the top oil fill tube, the fuel tank must be empty or fuel can leak out and result in a fire or explosion.

When Transporting Equipment

- Transport with fuel tank EMPTY or with fuel shut-off valve OFF.

When Storing Fuel Or Equipment With Fuel In Tank

- Store away from furnaces, stoves, water heaters or other appliances that have pilot lights or other ignition sources because they can ignite fuel vapors.

WARNING
 Starting engine creates sparking.
 Sparking can ignite nearby flammable gases.
 Explosion and fire could result.

- If there is natural or LP gas leakage in area, do not start engine.
- Do not use pressurized starting fluids because vapors are flammable.



 **WARNING**
Engines give off carbon monoxide, an odorless, colorless, poison gas. Breathing carbon monoxide can cause nausea, fainting or death.





- Start and run engine outdoors.
- Do not start or run engine in enclosed area, even if doors or windows are open.

 **WARNING**
Rapid retraction of starter cord (kickback) will pull hand and arm toward engine faster than you can let go.
Broken bones, fractures, bruises or sprains could result.





- When starting engine, pull the starter cord slowly until resistance is felt and then pull rapidly to avoid kickback.
- Remove all external equipment/engine loads before starting engine.
- Direct-coupled equipment components such as, but not limited to, blades, impellers, pulleys, sprockets, etc., must be securely attached.

 **WARNING**
Rotating parts can contact or entangle hands, feet, hair, clothing, or accessories.
Traumatic amputation or severe laceration can result.







- Operate equipment with guards in place.
- Keep hands and feet away from rotating parts.
- Tie up long hair and remove jewelry.
- Do not wear loose-fitting clothing, dangling drawstrings or items that could become caught.

 **WARNING**
Running engines produce heat. Engine parts, especially muffler, become extremely hot.
Severe thermal burns can occur on contact.
Combustible debris, such as leaves, grass, brush, etc. can catch fire.

- Allow muffler, engine cylinder and fins to cool before touching.
- Remove accumulated debris from muffler area and cylinder area.
- It is a violation of California Public Resource Code, Section 4442, to use or operate the engine on any forest-covered, brush-covered, or grass-covered land unless the exhaust system is equipped with a spark arrester, as defined in Section 4442, maintained in effective working order. Other states or federal jurisdictions may have similar laws. Contact the original equipment manufacturer, retailer, or dealer to obtain a spark arrester designed for the exhaust system installed on this engine.

 **WARNING**
Unintentional sparking can result in fire or electric shock.
Unintentional start-up can result in entanglement, traumatic amputation, or laceration.
Fire hazard

Before performing adjustments or repairs:

- Disconnect the spark plug wire and keep it away from the spark plug.
- Disconnect battery at negative terminal (only engines with electric start.)
- Use only correct tools.
- Do not tamper with governor spring, links or other parts to increase engine speed.
- Replacement parts must be of the same design and installed in the same position as the original parts. Other parts may not perform as well, may damage the unit, and may result in injury.
- Do not strike the flywheel with a hammer or hard object because the flywheel may later shatter during operation.

When testing for spark:

- Use approved spark plug tester.
- Do not check for spark with spark plug removed.



Features and Controls

Compare the illustration **1** with your engine to familiarize yourself with the location of various features and controls.

- A. Engine Identification
Model Type Code
- B. Spark Plug
- C. Fuel Tank and Cap
- D. Air Cleaner
- E. Starter Cord Handle
- F. Oil Fill and Dipstick
- G. Oil Drain Plug
- H. Muffler
Muffler Guard (optional)
Spark Arrester (optional)
- I. Choke Control
- J. Throttle Control (optional)
- K. TransportGuard™ - Fuel/Ignition Lever
- L. Finger Guard
- M. Gear Reduction Unit (optional)

Operation

Oil capacity (see the **Specifications** section)

Oil Recommendations

We recommend the use of Briggs & Stratton Warranty Certified oils for best performance. Other high-quality detergent oils are acceptable if classified for service SF, SG, SH, SJ or higher. Do not use special additives.

Outdoor temperatures determine the proper oil viscosity for the engine. Use the chart to select the best viscosity for the outdoor temperature range expected.

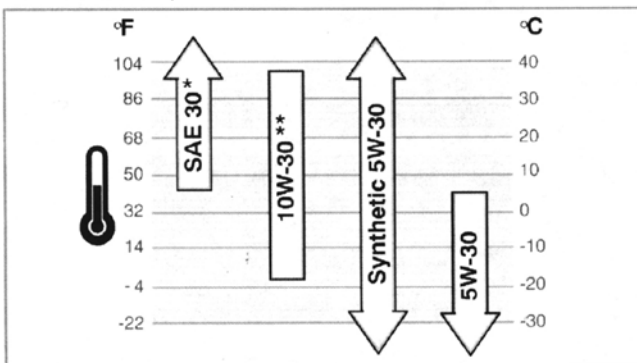

* Below 40°F (4°C) the use of SAE 30 will result in hard starting.

** Above 80°F (27°C) the use of 10W-30 may cause increased oil consumption. Check oil level more frequently.

How To Check/Add Oil - Figure 2

Before adding or checking the oil

- Place engine level.
- Clean the oil fill area of any debris.
- 1. Remove the dipstick (A) and wipe with a clean cloth.
- 2. Insert the dipstick. **Do not turn or tighten.**
- 3. Remove the dipstick and check the oil level. It should be at the top of the full indicator (B) on the dipstick.
- 4. To add oil, pour the oil slowly into the engine oil fill (C). Fill to point of overflowing.
- 5. Replace and tighten the dipstick.

Fuel Recommendations

Fuel must meet these requirements:

- Clean, fresh, unleaded gasoline.
- A minimum of 87 octane/87 AKI (91 RON). High altitude use, see below.
- Gasoline with up to 10% ethanol (gasohol) is acceptable.

CAUTION: Do not use unapproved gasolines, such as E15 and E85. Do not mix oil in gasoline or modify the engine to run on alternate fuels. This will damage the engine components and void the engine warranty.

To protect the fuel system from gum formation, mix a fuel stabilizer into the fuel. See **Storage**. All fuel is not the same. If starting or performance problems occur, change fuel providers or change brands. This engine is certified to operate on gasoline. The emissions control system for this engine is EM (Engine Modifications).

High Altitude

At altitudes over 5,000 feet (1524 meters), a minimum 85 octane/85 AKI (89 RON) gasoline is acceptable. To remain emissions compliant, high altitude adjustment is required. Operation without this adjustment will cause decreased performance, increased fuel consumption, and increased emissions. See a Briggs & Stratton Authorized Dealer for high altitude adjustment information.

Operation of the engine at altitudes below 2,500 feet (762 meters) with the high altitude kit is not recommended.

How To Add Fuel - Figure 3



WARNING



Fuel and its vapors are extremely flammable and explosive. Fire or explosion can cause severe burns or death.

When Adding Fuel

- Turn engine off and let engine cool at least 2 minutes before removing the fuel cap.
- Fill fuel tank outdoors or in well-ventilated area.
- Do not overfill fuel tank. To allow for expansion of the fuel, do not fill above the bottom of the fuel tank neck.
- Keep fuel away from sparks, open flames, pilot lights, heat, and other ignition sources.
- Check fuel lines, tank, cap, and fittings frequently for cracks or leaks. Replace if necessary
- If fuel spills, wait until it evaporates before starting engine.

1. Clean the fuel cap area of dirt and debris. Remove the fuel cap (A, Figure 3).
2. Fill the fuel tank (B) with fuel. To allow for expansion of the fuel, do not fill above the bottom of the fuel tank neck (C).
3. Reinstall the fuel cap.

How To Start The Engine - Figure 4



WARNING



Rapid retraction of starter cord (kickback) will pull hand and arm toward engine faster than you can let go. Broken bones, fractures, bruises or sprains could result.

- When starting engine, pull the starter cord slowly until resistance is felt and then pull rapidly to avoid kickback.



WARNING



Fuel and its vapors are extremely flammable and explosive. Fire or explosion can cause severe burns or death.

When Starting Engine

- Ensure that spark plug, muffler, fuel cap and air cleaner (if equipped) are in place and secured.
- Do not crank engine with spark plug removed.
- If engine floods, set choke (if equipped) to OPEN/RUN position, move throttle (if equipped) to FAST position and crank until engine starts.



WARNING



Engines give off carbon monoxide, an odorless, colorless, poison gas. Breathing carbon monoxide can cause nausea, fainting or death.

- Start and run engine outdoors.
- Do not start or run engine in enclosed area, even if doors or windows are open.

NOTICE: This engine was shipped from Briggs & Stratton without oil. Before you start the engine, make sure you add oil according to the instructions in this manual. If you start the engine without oil, it will be damaged beyond repair and will not be covered under warranty.

Note: Some engines and equipment have remote controls. See the equipment manual for location and operation of remote controls.

1. Check the oil level. See the **How To Check/Add Oil** section.
2. Make sure equipment drive controls, if equipped, are disengaged.
3. Move the fuel/ignition lever (A) to the on **1** position (Figure 4).
4. Move the throttle control (B), if equipped, to the fast position. Operate the engine in the fast position.



5. Move the choke control (C) to the choke position.
Note: Choke is usually unnecessary when restarting a warm engine.
6. **Rewind Start:** Firmly hold the starter cord handle (D). Pull the starter cord handle slowly until resistance is felt, then pull rapidly (Figure 4).
Note: If the engine does not start after repeated attempts, go to VanguardEngines.com or call 1-800-999-9333 (in USA).

WARNING: Rapid retraction of the starter cord (kickback) will pull your hand and arm toward the engine faster than you can let go. Broken bones, fractures, bruises or sprains could result. When starting engine, pull the starter cord slowly until resistance is felt and then pull rapidly to avoid kickback.

7. **Electric Start:** Turn the electric start switch to the on/start position.
Note: If the engine does not start after repeated attempts, go to VanguardEngines.com or call 1-800-999-9333 (in USA).

NOTICE: To extend the life of the starter, use short starting cycles (five seconds maximum). Wait one minute between starting cycles.

8. As the engine warms up, move the choke control (C) to the run position (Figure 4).

How To Stop The Engine - Figure 4



WARNING

Fuel and its vapors are extremely flammable and explosive. Fire or explosion can cause severe burns or death.

- Do not choke the carburetor to stop engine.

Move the fuel/ignition lever (A) to the off position.

Maintenance

We recommend that you see any Briggs & Stratton Authorized Dealer for all maintenance and service of the engine and engine parts.

NOTICE: All the components used to build this engine must remain in place for proper operation.

Emissions Control

Maintenance, replacement, or repair of the emissions control devices and systems may be performed by any non-road engine repair establishment or individual. However, to obtain "no charge" emissions control service, the work must be performed by a factory authorized dealer. See the Emissions Warranty.

WARNING
Unintentional sparking can result in fire or electric shock.
Unintentional start-up can result in entanglement, traumatic amputation, or laceration.
Fire hazard

Before performing adjustments or repairs:

- Disconnect the spark plug wire and keep it away from the spark plug.
- Disconnect battery at negative terminal (only engines with electric start).
- Use only correct tools.
- Do not tamper with governor spring, links or other parts to increase engine speed.
- Replacement parts must be of the same design and installed in the same position as the original parts. Other parts may not perform as well, may damage the unit, and may result in injury.
- Do not strike the flywheel with a hammer or hard object because the flywheel may later shatter during operation.

When testing for spark:

- Use approved spark plug tester.
- Do not check for spark with spark plug removed.

Maintenance Chart

First 5 Hours
<ul style="list-style-type: none"> • Change oil
Every 8 Hours or Daily
<ul style="list-style-type: none"> • Check engine oil level • Clean area around muffler and controls • Clean finger guard
Every 25 Hours or Annually
<ul style="list-style-type: none"> • Clean air filter * • Clean pre-cleaner *
Every 50 Hours or Annually
<ul style="list-style-type: none"> • Change engine oil • Check muffler and spark arrester
Every 100 Hours
<ul style="list-style-type: none"> • Change gear reduction oil (if equipped)
Annually
<ul style="list-style-type: none"> • Replace air filter • Replace pre-cleaner • Replace spark plug • Clean/Replace debris strainer • Clean air cooling system * • Check valve clearance. Adjust if necessary.

* In dusty conditions or when airborne debris is present, clean more often.

Carburetor Adjustment

Never make adjustments to the carburetor. The carburetor was set at the factory to operate efficiently under most conditions. However, if adjustments are required, see any Briggs & Stratton Authorized Dealer for service.

NOTICE: The manufacturer of the equipment on which this engine is installed specifies the top speed at which the engine will be operated. **Do not exceed** this speed.

How To Check The Spark Plug - Figure 5

Check the gap (A, Figure 5) with a wire gauge (B). If necessary, reset the gap. Install and tighten the spark plug to the recommended torque. For gap setting or torque, see the **Specifications** section.

Note: In some areas, local law requires using a resistor spark plug to suppress ignition signals. If this engine was originally equipped with a resistor spark plug, use the same type for replacement.



Inspect Muffler And Spark Arrester - Figure 6



WARNING



Running engines produce heat. Engine parts, especially muffler, become extremely hot.



Severe thermal burns can occur on contact.

Combustible debris, such as leaves, grass, brush, etc. can catch fire.

- Allow muffler, engine cylinder and fins to cool before touching.
- Remove accumulated debris from muffler area and cylinder area.
- It is a violation of California Public Resource Code, Section 4442, to use or operate the engine on any forest-covered, brush-covered, or grass-covered land unless the exhaust system is equipped with a spark arrestor, as defined in Section 4442, maintained in effective working order. Other states or federal jurisdictions may have similar laws. Contact the original equipment manufacturer, retailer, or dealer to obtain a spark arrestor designed for the exhaust system installed on this engine.

Remove accumulated debris from muffler area and cylinder area. Inspect the muffler (A, Figure 6) for cracks, corrosion, or other damage. Remove the spark arrestor (B), if equipped, and inspect for damage or carbon blockage. If damage is found, install replacement parts before operating.



WARNING: Replacement parts must be of the same design and installed in the same position as the original parts. Other parts may not perform as well, may damage the unit, and may result in injury.

How To Change The Oil - Figure 7 8

Used oil is a hazardous waste product and must be disposed of properly. Do not discard with household waste. Check with your local authorities, service center, or dealer for safe disposal/recycling facilities.

Remove Oil

1. With engine off but still warm, disconnect the spark plug wire (A) and keep it away from the spark plug (Figure 7).
2. Remove the oil drain plug (B, Figure 8). Drain the oil into an approved receptacle.
Note: Any of the oil drain plugs shown below may be installed in the engine.



3. After the oil has drained, install and tighten the oil drain plug.

Add oil

- Place engine level.
 - Clean the oil fill area of any debris.
 - See the **Specifications** section for oil capacity.
1. Remove the dipstick (D) and wipe with a clean cloth.
 2. Pour the oil slowly into the engine oil fill (E). Fill to point of overflowing.
 3. Insert the dipstick. **Do not turn or tighten.**
 4. Remove the dipstick and check the oil level. It should be at the top of the full indicator (F) on the dipstick.
 5. Install and tighten the dipstick.

How To Service The Air Filter - Figure 9 10



WARNING



Fuel and its vapors are extremely flammable and explosive. Fire or explosion can cause severe burns or death.



- Never start or run the engine with the air cleaner assembly (if equipped) or the air filter (if equipped) removed.

NOTICE: Do not use pressurized air or solvents to clean the filter. Pressurized air can damage the filter and solvents will dissolve the filter.

Two types of air filter systems are shown, a **Standard** and a **High Capacity**. Determine the type installed on your engine and service as follows.

Standard Air Filter - Figure 9

The standard air filter uses a foam element that can be washed and reused.

1. Loosen the fastener (A) that holds the cover (B). Remove the cover.
2. Remove the fastener (C), the washer (D), and the foam element (E).
3. Remove the support cup (F) from the foam element.
4. Wash the foam element in liquid detergent and water. Squeeze dry the foam element in a clean cloth.

5. Saturate the foam element with clean engine oil. To remove the excess engine oil, squeeze the foam element in a clean cloth.
6. Insert the support cup into the foam element.
7. Install the foam element into the base (G) and onto stud (H). Make sure foam element is properly assembled into base and secure with the washer and the fastener.
8. Install the air filter cover and secure with the fastener. Make sure the fastener is tight.

High Capacity Air Filter - Figure 10

The air cleaner system uses a pleated filter with an optional pre-cleaner. The pre-cleaner can be washed and reused.

1. Loosen the fastener (A) that holds the cover (B). Remove the cover.
2. Remove the fastener (C), the pre-cleaner (D), if equipped, and the filter (E).
3. Remove the pre-cleaner, if equipped, from the filter. To loosen debris, gently tap the filter on a hard surface. If the filter is excessively dirty, replace with a new filter.
4. Wash the pre-cleaner in liquid detergent and water. Then allow it to thoroughly air dry. **Do not** oil the pre-cleaner.
5. Assemble the dry pre-cleaner to the filter.
6. Install the seal washer (F), the filter, and the pre-cleaner, if equipped, into the base (G) and onto stud (H). Make sure filter is properly assembled into base and secure with the fastener.
7. Install the air filter cover and secure with the fastener. Make sure the fastener is tight.

How To Change The Gear Reduction Oil - Figure 11

If your engine is equipped with a gear reduction unit, service as follows.

1. Remove the oil fill plug (B) and the oil level plug (C).
2. Remove the oil drain plug (A, Figure 11) and drain the oil into an appropriate receptacle.
3. Install and tighten the oil drain plug.
4. To refill, slowly pour gear lube into the oil fill hole (see **Specifications** section). Continue to pour until the oil runs out of the oil level hole.
5. Install and tighten the oil level plug.
6. Install and tighten the oil fill plug.
Important: The oil fill plug has a vent hole (D) and must be installed on the top of the gear case cover as shown.

How To Clean/Replace The Debris Strainer - Figure 12



WARNING



Fuel and its vapors are extremely flammable and explosive. Fire or explosion can cause severe burns or death.



- Keep fuel away from sparks, open flames, pilot lights, heat, and other ignition sources.
- Check fuel lines, tank, cap, and fittings frequently for cracks or leaks. Replace if necessary.
- Replacement parts must be the same and installed in the same position as the original parts.
- If fuel spills, wait until it evaporates before starting engine.

1. Remove the fuel cap (A, Figure 12).
2. Remove the debris strainer (B).
3. If the debris strainer is dirty, clean or replace it. If you replace the debris strainer, make sure to use an original equipment replacement debris strainer.

How To Clean The Air Cooling System - Figure 13



WARNING



Running engines produce heat. Engine parts, especially muffler, become extremely hot.



Severe thermal burns can occur on contact.

Combustible debris, such as leaves, grass, brush, etc. can catch fire.

- Allow muffler, engine cylinder and fins to cool before touching.
- Remove accumulated debris from muffler area and cylinder area.

NOTICE: Do not use water to clean the engine. Water could contaminate the fuel system. Use a brush or dry cloth to clean the engine.

This is an air cooled engine. Dirt or debris can restrict air flow and cause the engine to overheat, resulting in poor performance and reduced engine life.

Use a brush or dry cloth to remove debris from the finger guard (A). Keep linkage, springs and controls (B) clean. Keep the area around and behind the muffler (C) free of any combustible debris (Figure 13).

After a period of time, debris can accumulate in the cylinder cooling fins and cause the engine to overheat. This debris cannot be removed without partial disassembly of the engine. Have a Briggs & Stratton Authorized Dealer inspect and clean the air cooling system as recommended in the **Maintenance Chart**.



Storage



WARNING

Fuel and its vapors are extremely flammable and explosive. Fire or explosion can cause severe burns or death.



When Storing Fuel Or Equipment With Fuel In Tank

- Store away from furnaces, stoves, water heaters or other appliances that have pilot light or other ignition source because they can ignite fuel vapors.

Fuel System

Fuel can become stale when stored over 30 days. Stale fuel causes acid and gum

deposits to form in the fuel system or on essential carburetor parts. To keep fuel fresh, use Briggs & Stratton FRESH START® fuel stabilizer, available as a liquid additive or a drip concentrate cartridge.

There is no need to drain gasoline from the engine if a fuel stabilizer is added according to instructions. Run the engine for 2 minutes to circulate the stabilizer throughout the fuel system. The engine and fuel can then be stored up to 24 months.

If gasoline in the engine has not been treated with a fuel stabilizer, it must be drained into an approved container. Run the engine until it stops from lack of fuel. The use of a fuel stabilizer in the storage container is recommended to maintain freshness.

Engine Oil

While the engine is still warm, change the engine oil.

Troubleshooting

Need Assistance? Go to VanguardEngines.com or call 1-800-999-9333.

Specifications

Engine Specifications	
Model	130000
Displacement	12.48 ci (205 cc)
Bore	2.688 in (68.28 mm)
Stroke	2.200 in (55.88 mm)
Engine Oil Capacity	20 - 22 oz (0.59 - 0.65 L)

Gear Reduction Specifications	
Gear Reduction Oil Type	80W-90
Gear Reduction Oil Capacity	4 oz (0.12 L)

Tune-up Specifications *	
Model	130000
Spark Plug Gap	0.030 in (0.76 mm)
Spark Plug Torque	180 lb-in (20 Nm)
Armature Air Gap	0.010 - 0.014 in (0.25 - 0.36 mm)
Intake Valve Clearance	0.004 - 0.006 in (0.10 - 0.15 mm)
Exhaust Valve Clearance	0.009 - 0.011 in (0.23 - 0.28 mm)

Engine Specifications	
Model	190000
Displacement	18.63 ci (305 cc)
Bore	3.120 in (79.24 mm)
Stroke	2.438 in (61.93 mm)
Engine Oil Capacity	26 - 28 oz (0.77 - 0.83 L)

Gear Reduction Specifications	
Gear Reduction Oil Type	SAE 30
Gear Reduction Oil Capacity	12 oz (0.35 L)

Tune-up Specifications *	
Model	190000
Spark Plug Gap	0.030 in (0.76 mm)
Spark Plug Torque	180 lb-in (20 Nm)
Armature Air Gap	0.010 - 0.014 in (0.25 - 0.36 mm)
Intake Valve Clearance	0.004 - 0.006 in (0.10 - 0.15 mm)
Exhaust Valve Clearance	0.004 - 0.006 in (0.10 - 0.15 mm)

* Engine power will decrease 3.5% for each 1,000 feet (300 meters) above sea level and 1% for each 10° F (5.6° C) above 77° F (25° C). The engine will operate satisfactorily at an angle up to 15°. Refer to the equipment operator's manual for safe allowable operating limits on slopes.

Common Service Parts ✓

Service Part	Part Number
High Capacity Air Filter, Model 130000	797033
High Capacity Air Filter Pre-cleaner, Model 130000	798513
High Capacity Air Filter, Model 190000	797032
High Capacity Air Filter Pre-cleaner, Model 190000	798795
Standard Air Filter, Model 130000	797378

Service Part	Part Number
Fuel Additive	5041, 5058
Resistor Spark Plug	491055
Spark Plug Wrench	19576, 5402
Spark Tester	19368

✓ We recommend that you see any Briggs & Stratton Authorized Dealer for all maintenance and service of the engine and engine parts.



BRIGGS & STRATTON ENGINE OWNER WARRANTY POLICY

July 2010

LIMITED WARRANTY

Briggs & Stratton Corporation will repair or replace, free of charge, any part(s) of the engine that is defective in material or workmanship or both. Transportation charges on product submitted for repair or replacement under this warranty must be borne by purchaser. This warranty is effective for and is subject to the time periods and conditions stated below. For warranty service, find the nearest Authorized Service Dealer in our dealer locator map at BRIGGSandSTRATTON.COM, or by calling 1-800-233-3723, or as listed in the 'Yellow Pages'.

There is no other expressed warranty. Implied warranties, including those of merchantability and fitness for a particular purpose, are limited to one year from purchase, or to the extent permitted by law. All other implied warranties are excluded. Liability for incidental or consequential damages are excluded to the extent exclusion is permitted by law. Some states or countries do not allow limitations on how long an implied warranty lasts, and some states or countries do not allow the exclusion or limitation of incidental or consequential damages, so the above limitation and exclusion may not apply to you. This warranty gives you specific legal rights and you may also have other rights which vary from state to state and country to country.

STANDARD WARRANTY TERMS * ▲

Brand/Product Type	Consumer Use	Commercial Use
Vanguard™ ■	3 years	3 years
Extended Life Series™ ; I/C®; Intek™ I/C®; Intek™ Pro; Commercial Turf Series™ Professional Series™ with Dura-Bore™ Cast Iron Sleeve; 850 Series™ with Dura-Bore™ Cast Iron Sleeve; Snow Series MAX™ with Dura-Bore™ Cast Iron Sleeve All Other Briggs & Stratton Engines Featuring Dura-Bore™ Cast Iron Sleeve	2 years	1 year
All Other Briggs & Stratton Engines	2 years	90 days

* These are our standard warranty terms, but occasionally there may be additional warranty coverage that was not determined at time of publication. For a listing of current warranty terms for your engine, go to BRIGGSandSTRATTON.COM or contact your Authorized Briggs & Stratton Service Dealer.

▲ Home Standby Generator applications: 2 years consumer warranty only. No commercial warranty. This warranty does not apply to engines on equipment used for prime power in place of a utility. **Engines used in competitive racing or on commercial or rental tracks are not warranted.**

■ Vanguard installed on standby generators: 2 years consumer use, no warranty commercial use. Vanguard installed on utility vehicles: 2 years consumer use, 2 years commercial use. Vanguard 3-cylinder liquid cooled: see Briggs & Stratton 3/LC Engine Owner Warranty Policy.

The warranty period begins on the date of purchase by the first retail consumer or commercial end user, and continues for the period of time stated in the table above. "Consumer use" means personal residential household use by a retail consumer. "Commercial use" means all other uses, including use for commercial, income producing or rental purposes. Once an engine has experienced commercial use, it shall thereafter be considered as a commercial use engine for purposes of this warranty.

No warranty registration is necessary to obtain warranty on Briggs & Stratton Products. Save your proof of purchase receipt. If you do not provide proof of the initial purchase date at the time warranty service is requested, the manufacturing date of the product will be used to determine the warranty period.

About Your Warranty

Briggs & Stratton welcomes warranty repair and apologizes to you for being inconvenienced. Any Authorized Service Dealer may perform warranty repairs. Most warranty repairs are handled routinely, but sometimes requests for warranty service may not be appropriate.

If a customer differs with the decision of the Service Dealer, an investigation will be made to determine whether the warranty applies. Ask the Service Dealer to submit all supporting facts to his Distributor or the Factory for review. If the Distributor or the Factory decides that the claim is justified, the customer will be fully reimbursed for those items that are defective. To avoid misunderstanding which might occur between the customer and the Dealer, listed below are some of the causes of engine failure that the warranty does not cover.

Normal wear: Engines, like all mechanical devices, need periodic parts service and replacement to perform well. Warranty will not cover repair when normal use has exhausted the life of a part or an engine. Warranty would not apply if engine damage occurred because of misuse, lack of routine maintenance, shipping, handling, warehousing or improper installation. Similarly, warranty is void if the serial number of the engine has been removed or the engine has been altered or modified.

Improper maintenance: The life of an engine depends upon the conditions under which it operates, and the care it receives. Some applications, such as tillers, pumps and rotary mowers, are very often used in dusty or dirty conditions, which can cause what appears to be premature wear. Such wear, when caused by dirt, dust, spark plug cleaning grit, or other abrasive material that has entered the engine because of improper maintenance, is not covered by warranty.

This warranty covers engine related defective material and/or workmanship only, and not replacement or refund of the equipment to which the engine may be mounted. Nor does the warranty extend to repairs required because of:

- 1 Problems caused by parts that are not original Briggs & Stratton parts.
- 2 Equipment controls or installations that prevent starting, cause unsatisfactory engine performance, or shorten engine life. (Contact equipment manufacturer.)

- 3 Leaking carburetors, clogged fuel pipes, sticking valves, or other damage, caused by using contaminated or stale fuel.
- 4 Parts which are scored or broken because an engine was operated with insufficient or contaminated lubricating oil, or an incorrect grade of lubricating oil (check and refill when necessary, and change at recommended intervals). OIL GARD may not shut down running engine. Engine damage may occur if oil level is not properly maintained.
- 5 Repair or adjustment of associated parts or assemblies such as clutches, transmissions, remote controls, etc., which are not manufactured by Briggs & Stratton.
- 6 Damage or wear to parts caused by dirt, which entered the engine because of improper air cleaner maintenance, re-assembly, or use of a non-original air cleaner element or cartridge. At recommended intervals, clean and/or replace the filter as stated in the Operator's Manual.
- 7 Parts damaged by over-speeding, or overheating caused by grass, debris, or dirt, which plugs or clogs the cooling fins, or flywheel area, or damage caused by operating the engine in a confined area without sufficient ventilation. Clean engine debris at recommended intervals as stated in the Operator's Manual.
- 8 Engine or equipment parts broken by excessive vibration caused by a loose engine mounting, loose cutter blades, unbalanced blades or loose or unbalanced impellers, improper attachment of equipment to engine crankshaft, over-speeding or other abuse in operation.
- 9 A bent or broken crankshaft, caused by striking a solid object with the cutter blade of a rotary lawn mower, or excessive v-belt tightness.
- 10 Routine tune-up or adjustment of the engine.
- 11 Engine or engine component failure, i.e., combustion chamber, valves, valve seats, valve guides, or burned starter motor windings, caused by the use of alternate fuels such as, liquified petroleum, natural gas, altered gasolines, etc.

Warranty service is available only through authorized service dealers by Briggs & Stratton Corporation. Locate your nearest Authorized Service Dealer in our dealer locator map on BRIGGSandSTRATTON.COM or by calling 1-800-233-3723, or as listed in the 'Yellow Pages'.



California, U.S. EPA, and Briggs & Stratton Corporation Emissions Control Warranty Statement January 2011
Your Warranty Rights And Obligations

The California Air Resources Board, U.S. EPA, and Briggs & Stratton (B&S) are pleased to explain the emissions control system warranty on your Model Year 2011-2012 engine/equipment.

Your emissions control system may include parts such as the carburetor or fuel injection system, fuel tank, ignition system, and catalytic converter.

Where a warrantable condition exists, B&S will repair your engine/equipment at no cost to you including diagnosis, parts, and labor.

Manufacturer's Warranty Coverage:

Small off-road engines and large spark ignited engines less than or equal to 1.0 liter are warranted for three years.

Owner's Warranty Responsibilities:

- As the engine/equipment owner, you are responsible for the performance of the required maintenance listed in your owner's manual.
As the engine/equipment owner, you should however be aware that B&S may deny you warranty coverage if your engine/equipment or a part has failed due to abuse, neglect, improper maintenance, or unapproved modifications.
You are responsible for presenting your engine/equipment to a B&S distribution center, servicing dealer, or other equivalent entity, as applicable, as soon as a problem exists.

Briggs & Stratton Emissions Control Warranty Provisions

The following are specific provisions relative to your Emissions Control Warranty Coverage. It is in addition to the B&S engine warranty for non-regulated engines found in the Operator's Manual.

1. Warranted Emissions Parts

Coverage under this warranty extends only to the parts listed below (the emissions control systems parts) to the extent these parts were present on the engine purchased.

- Fuel Metering System
Cold start enrichment system (soft choke)
Carburetor and internal parts
Fuel pump
Fuel line, fuel line fittings, clamps
Fuel tank, cap and tether
Carbon canister
Air Induction System
Air cleaner
Intake manifold
Purge and vent line
Ignition System
Spark plug(s)
Magneto ignition system
Catalyst System
Catalytic converter
Exhaust manifold
Air injection system or pulse valve
Miscellaneous Items Used in Above Systems
Vacuum, temperature, position, time sensitive valves and switches
Connectors and assemblies

2. Length of Coverage

For a period of three years from date of original purchase, B&S warrants to the original purchaser and each subsequent purchaser that the engine is designed, built, and equipped so as to conform with all applicable regulations adopted by the Air Resources Board; that it is free from defects in material and workmanship that could cause the failure of a warranted part; and that it is identical in all material respects to the engine described in the manufacturer's application for certification.

The warranty on emissions-related parts is as follows:

- Any warranted part that is not scheduled for replacement as required maintenance in the owner's manual supplied, is warranted for the warranty period stated above.
Any warranted part that is scheduled only for regular inspection in the owner's manual supplied, is warranted for the warranty period stated above.
Any warranted part that is scheduled for replacement as required maintenance in the owner's manual supplied, is warranted for the period of time prior to the first scheduled replacement point for that part.
Add on or modified parts that are not exempted by the Air Resources Board may not be used.

3. Consequential Coverage

Coverage shall extend to the failure of any engine components caused by the failure of any warranted emissions parts.

4. Claims and Coverage Exclusions

Warranty claims shall be filed according to the provisions of the B&S engine warranty policy. Warranty coverage does not apply to failures of emissions parts that are not original equipment B&S parts or to parts that fail due to abuse, neglect, or improper maintenance as set forth in the B&S engine warranty policy.

Look For Relevant Emissions Durability Period and Air Index Information On Your Small Off-Road Engine Emissions Label

Engines that are certified to meet the California Air Resources Board (CARB) small off-road Emissions Standard must display information regarding the Emissions Durability Period and the Air Index.

The Emissions Durability Period describes the number of hours of actual running time or which the engine is certified to be emissions compliant, assuming proper maintenance in accordance with the Operating & Maintenance Instructions.

Moderate:

Engine is certified to be emissions compliant for 125 hours of actual engine running time.

Intermediate:

Engine is certified to be emissions compliant for 250 hours of actual engine running time.

Extended:

Engine is certified to be emissions compliant for 500 hours of actual engine running time. For example, a typical walk-behind lawn mower is used 20 to 25 hours per year.

Therefore, the Emissions Durability Period of an engine with an intermediate rating would equate to 10 to 12 years.

Briggs & Stratton engines are certified to meet the United States Environmental Protection Agency (USEPA) Phase 2 emissions standards. For Phase 2 certified engines, the Emissions Compliance Period referred to on the Emissions Compliance label indicates the number of operating hours for which the engine has been shown to meet Federal emissions requirements.

For engines less than 225 cc displacement. Category C = 125 hours, Category B = 250 hours, Category A = 500 hours

For engines of 225 cc or more displacement. Category C = 250 hours, Category B = 500 hours, Category A = 1000 hours

Maschinenfabrik Bermatingen
GmbH & CoKG.



custom equipment for
environmentally sound
utilisation of materials



mulching equipment for fruit
and wine growing, and
community services



compacting systems for
the volume reduction of
recyclable materials